

Lunar Regolith Temperature as a Monitor of the Radiation Budget of Earth

Shaopeng Huang

Department of Geological Sciences
University of Michigan

Key Points

- The Moon is a unique laboratory for investigation of the radiation budget of the climate system of Earth.
- Lunar surface temperature carries important information on both solar and terrestrial radiation.
- Subsurface temperature is the only known index of a past climate history on the Moon.

The Moon is a unique laboratory for investigation of the radiation budget of the climate system of Earth.

Earth Climate System

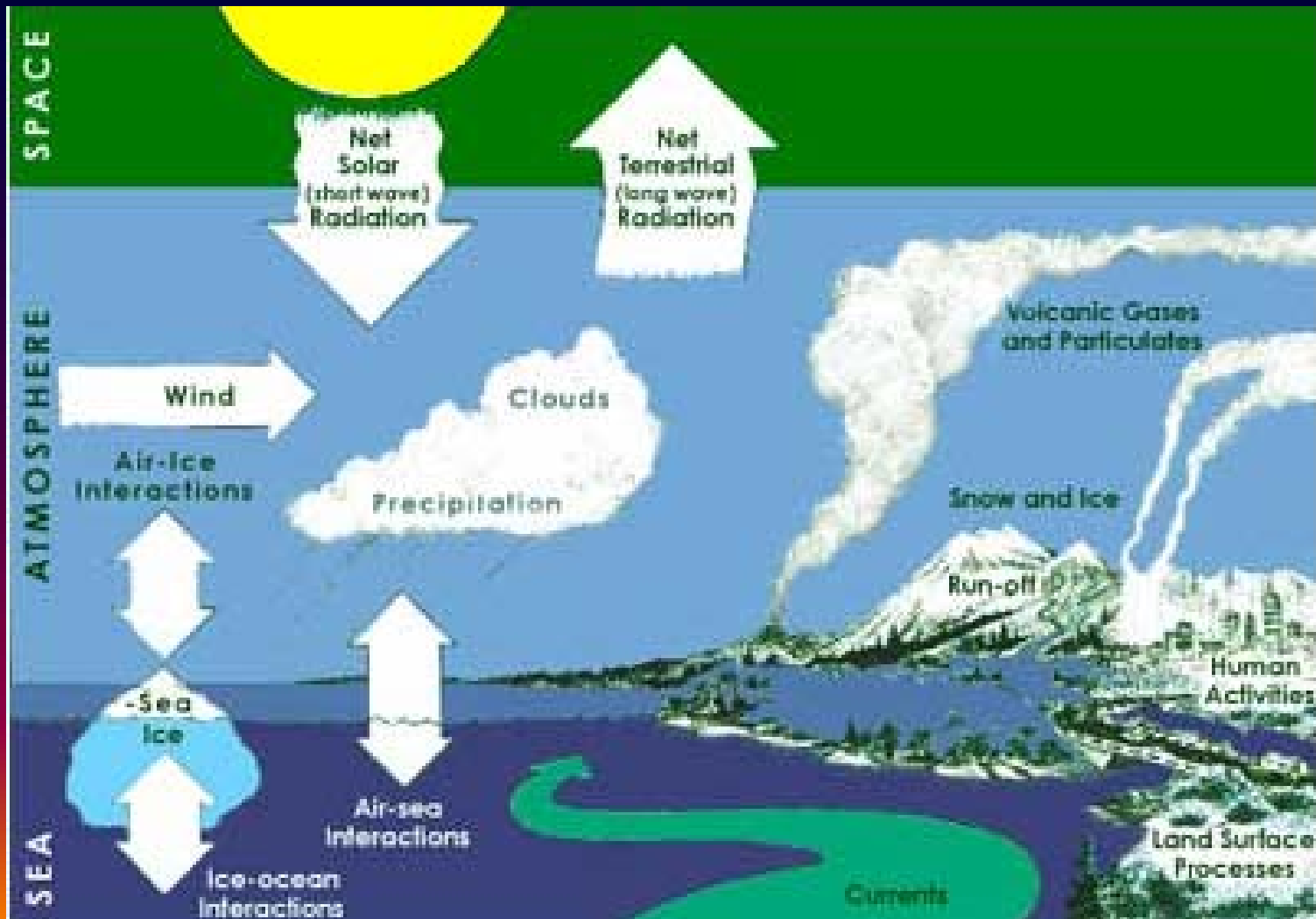

Downloaded from Climatewatch.Net with slight modification

Lunar Advantages

- Free of complications from atmosphere, biosphere, and hydrosphere
- Natural satellite with well known orbit allowing for precise data calibration
- Better position to take a global mean value for Earth
- A far side and a near side to focus on solar and terrestrial radiation

Sun-Earth-Moon

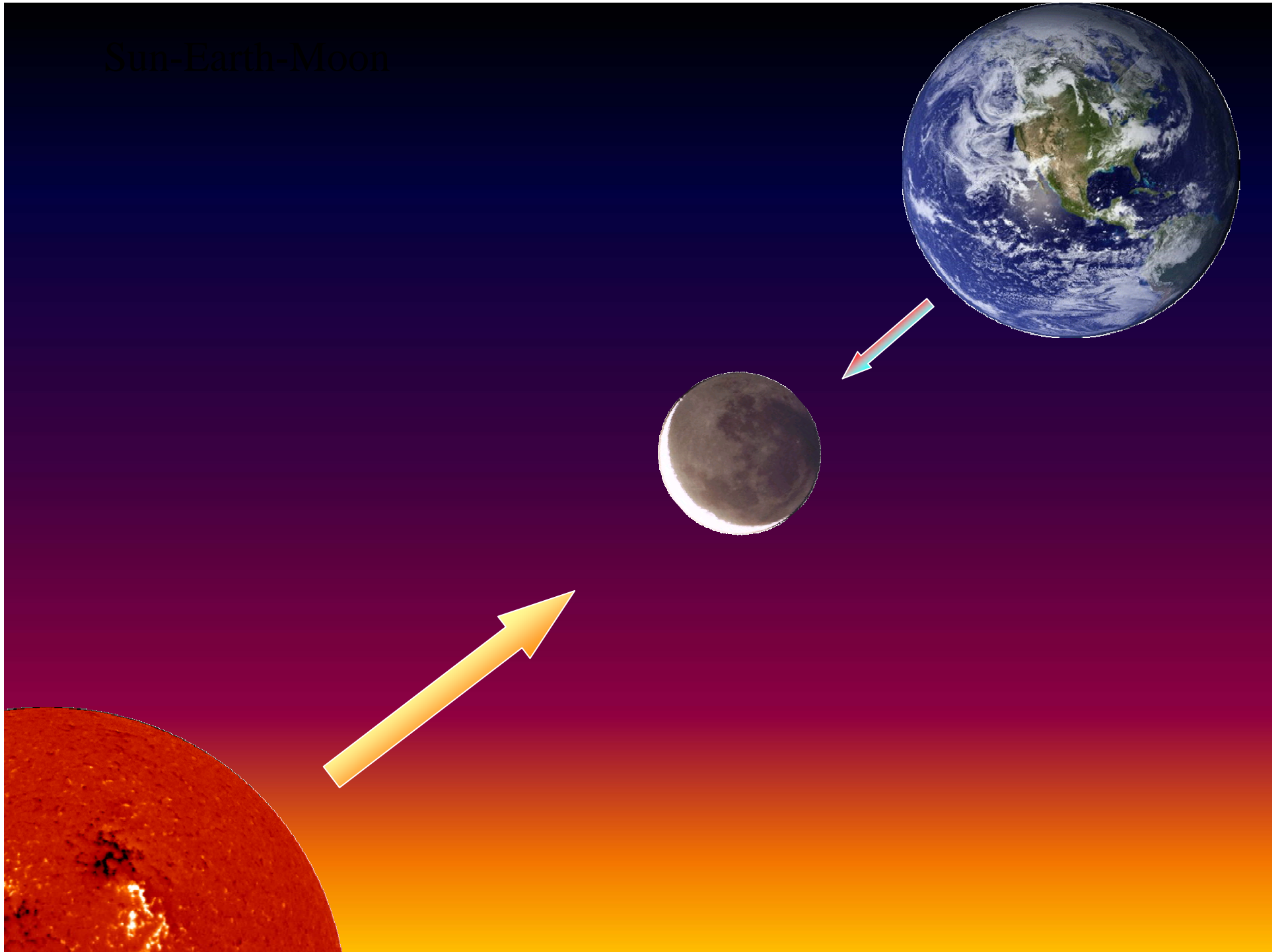

Lunar surface temperature
carries important
information on both
solar and terrestrial radiation.

Apollo 15 Heat Flow Experiment Deployment

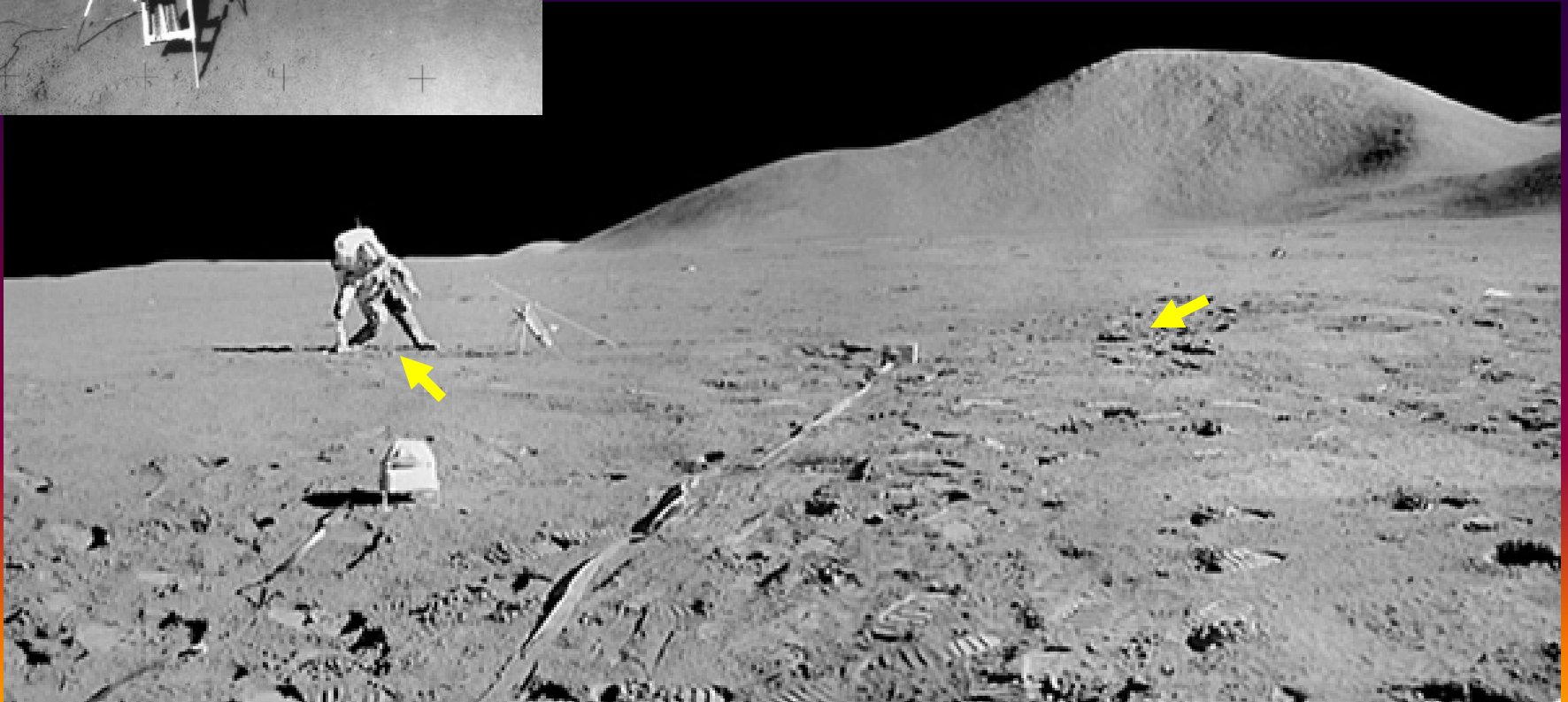
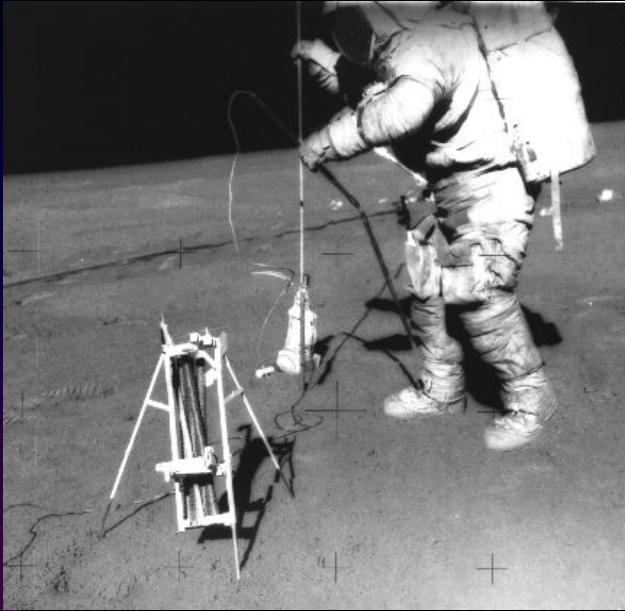
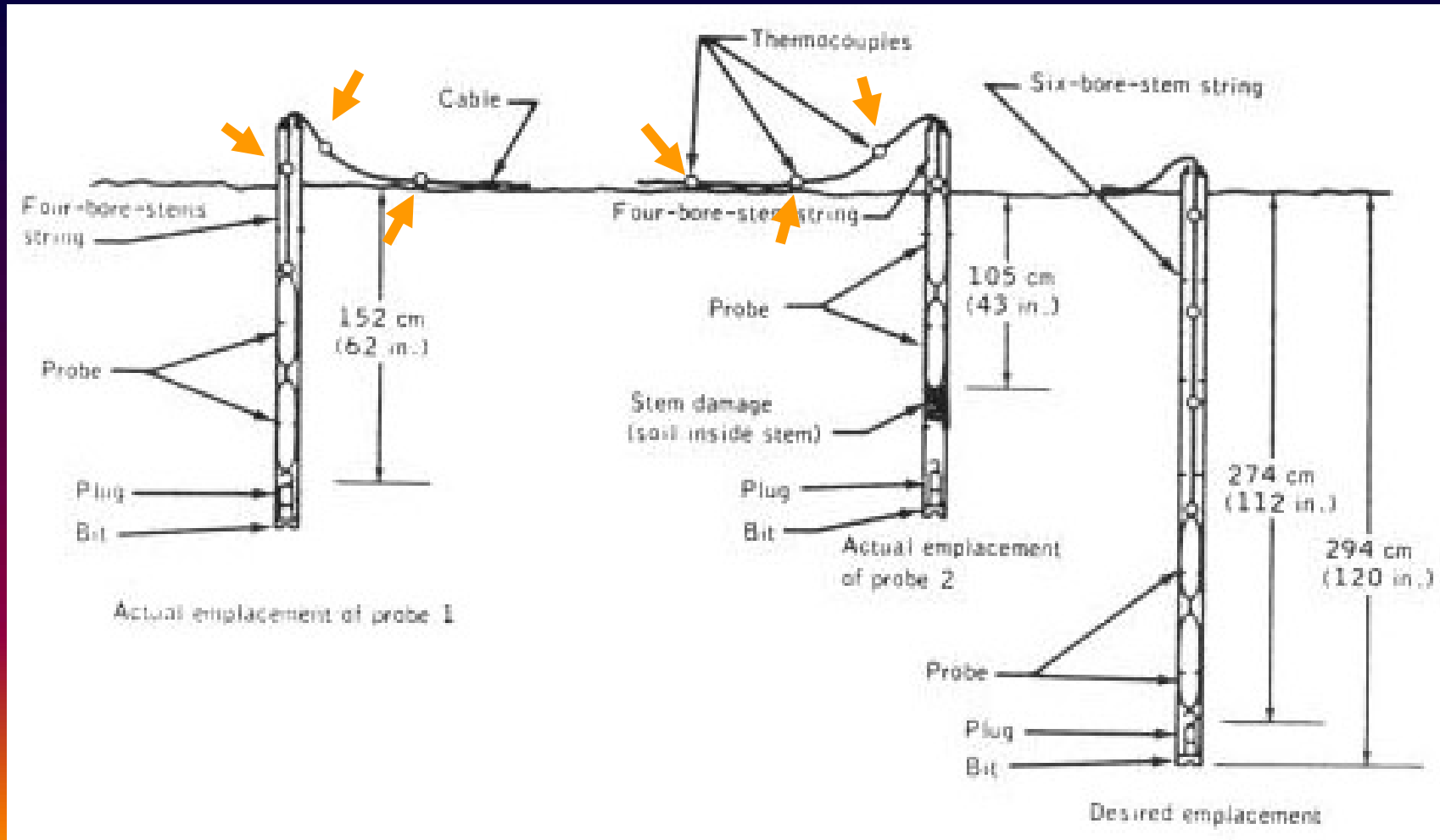

Photo credit: NASA

Apollo 15 Heat Flow Probes



Langseth et al., in Apollo 15 Prelim. Sic. Rep.

Sample: Apollo 15 TC 22

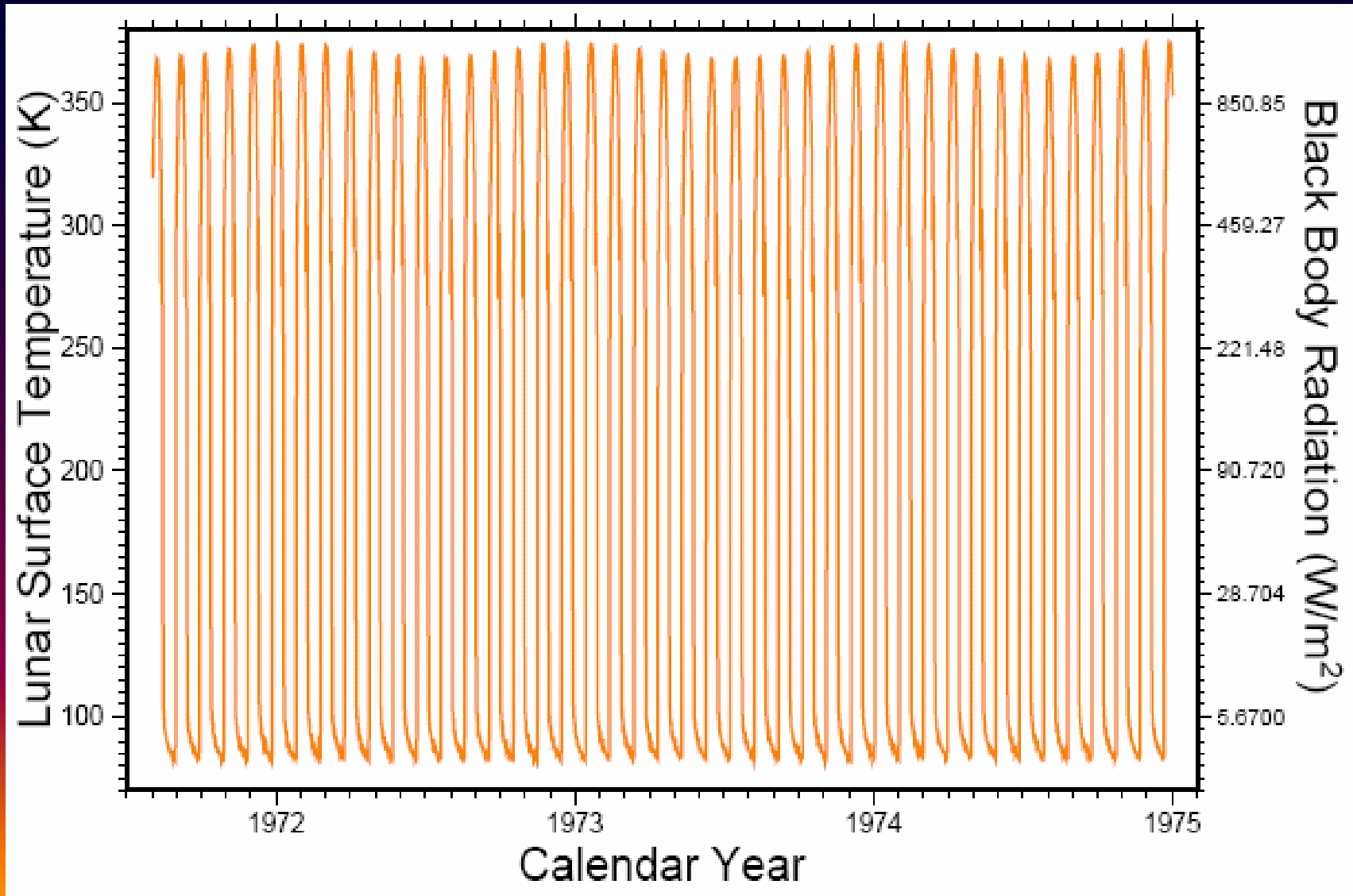

Apollo 15 TC22 Highs & Lows

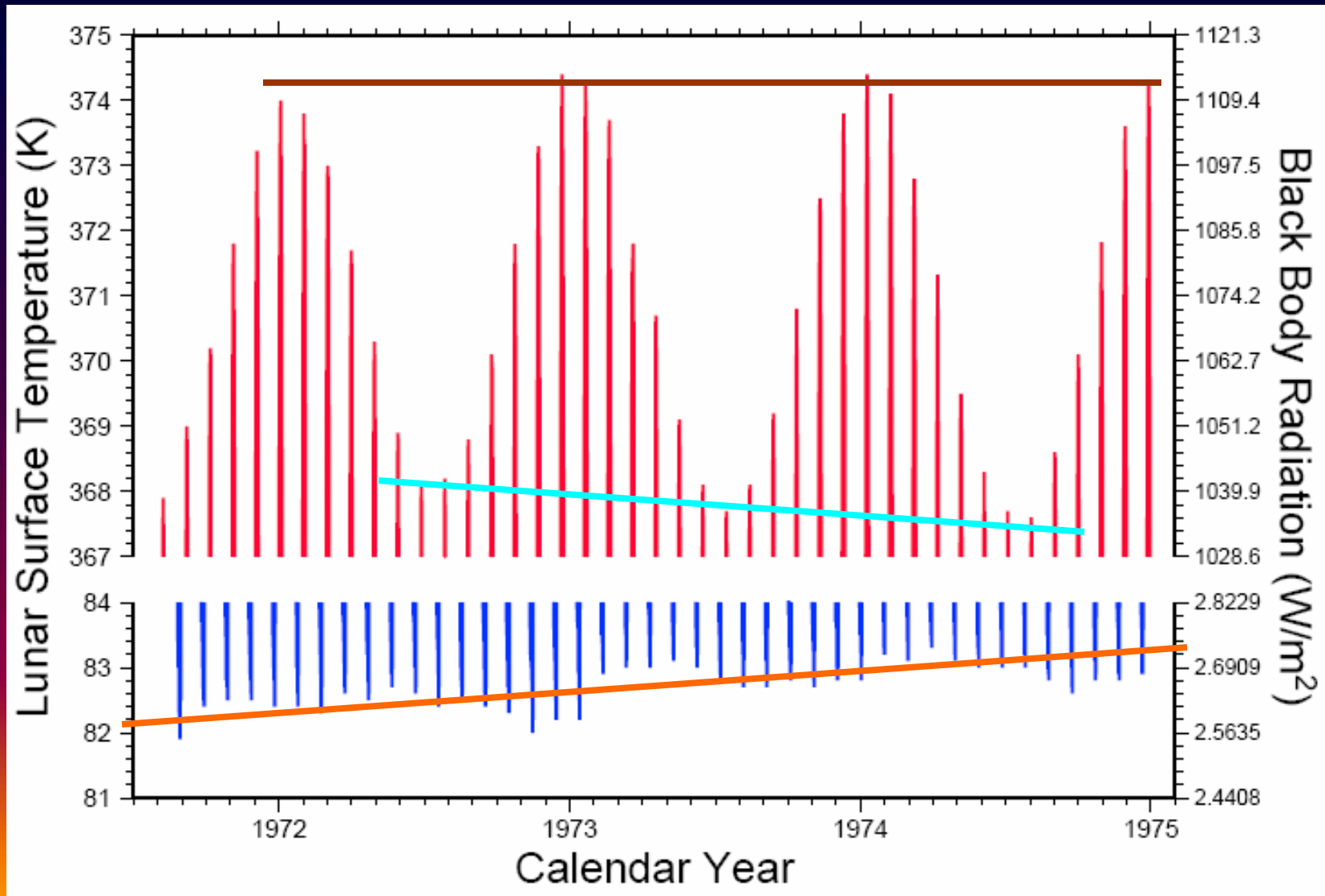

Subsurface temperature
is the only known index of a past
climate history on the Moon.

Borehole Thermometry

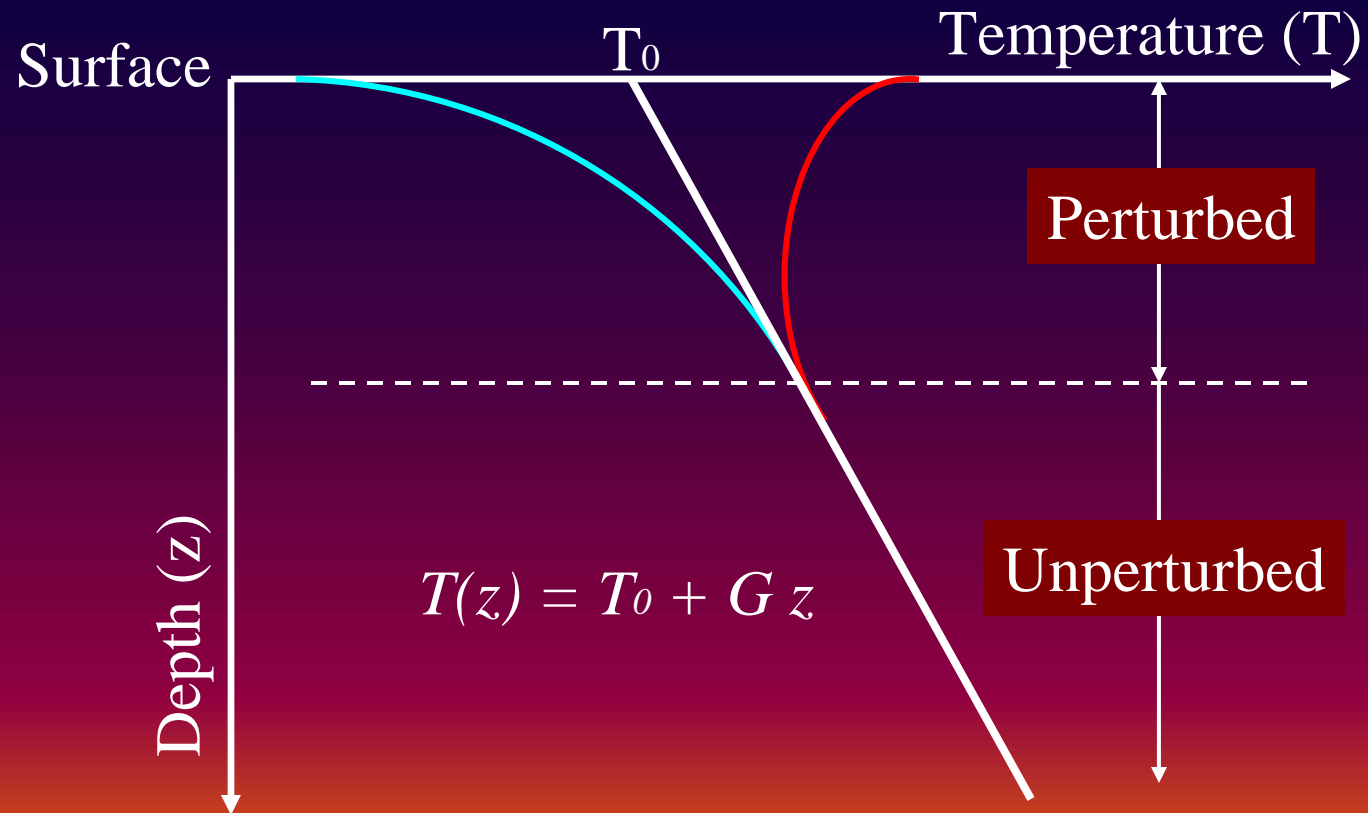

Lunar Borehole Approach

- Free of complication from many commonly seen perturbations on Earth
- Thick regolith layer favorable for drilling and/or probe penetration
- Extremely low thermal diffusivity and slow signal propagation

Thermophysical Properties

- **Crustal Rocks**

Conductivity 1.0-5.0 W/m/K

Diffusivity 0.8-1.2 10^{-6} m²/sec

- **Lunar regolith (Langseth et al., 1976)**

Conductivity 0.009-0.013 W/m/K

Diffusivity 0.002-0.01 10^{-6} m²/sec

- **Used in the Numerical Experiment**

Conductivity 0.02 W/m/K

Diffusivity 0.01 10^{-6} m²/sec

Numerical Experiment

Earth Northern and Southern Hemisphere SAT Scenarios

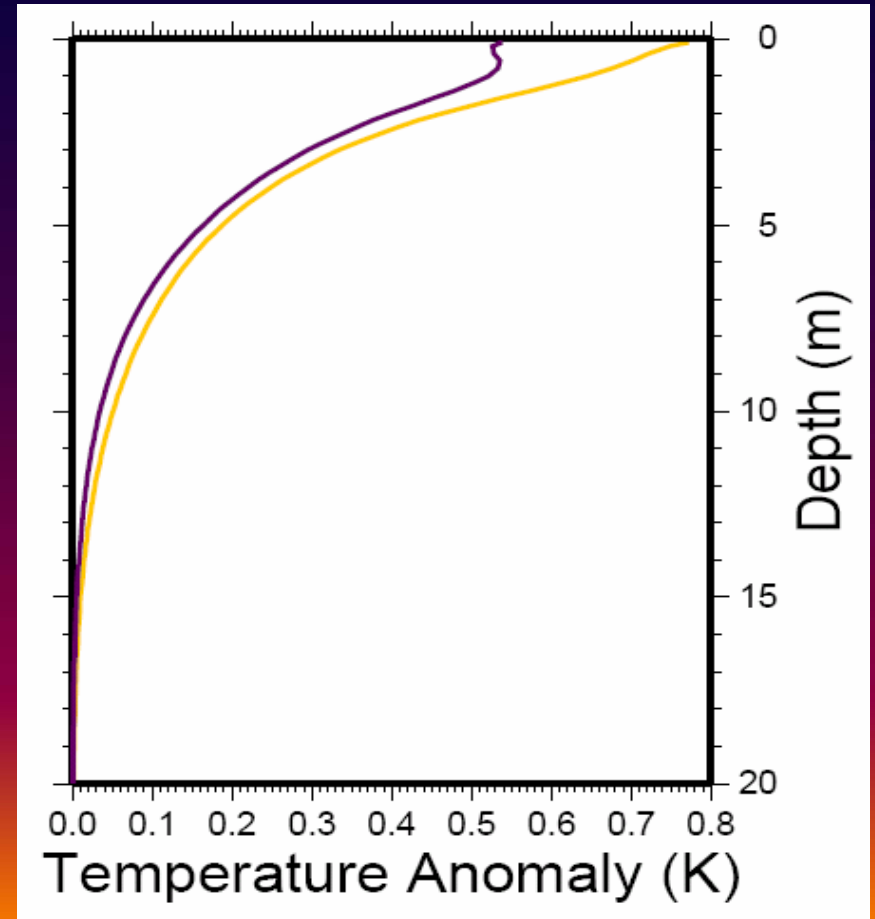
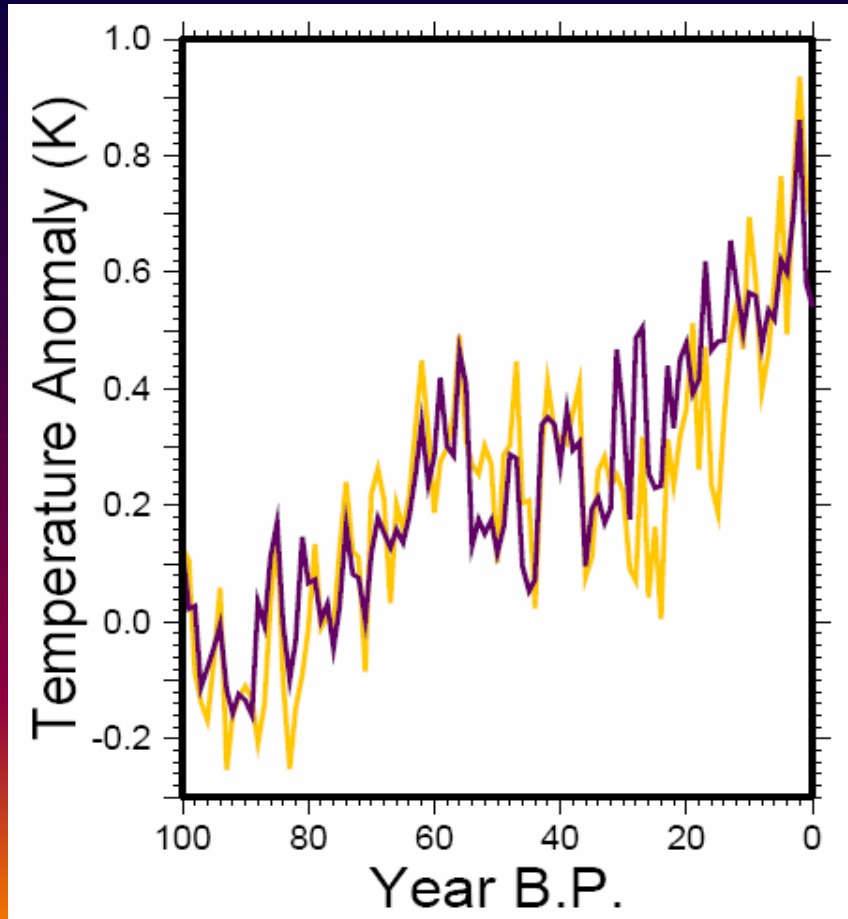

- **This study illustrates the great potential of the Moon as a new platform for the study of solar radiation and terrestrial climate change.**
- **I call for international efforts to establish a permanent temperature and radiation network, and borehole observatories on the Moon.**
- Support for my traveling to this meeting comes from NSF Grant ATM-0317572.